

# FICHE D'HOMOLOGATION / HOMOLOGATION FORM





041-EM-99



## COMMISSION INTERNATIONALE DE KARTING - FIA



### MOTEUR / ENGINE MINI

Constructeur / <i>Manufacturer</i>	TM RACING SPA
Marque / <i>Make</i>	TM KART
Modèle / <i>Model</i>	MIN 3B
Catégorie / <i>Categorie</i>	Group 3
Durée de l'homologation / <i>Validity of the Homologation</i>	3 ans / 3 years
Nombre de pages / <i>Number of pages</i>	14
La présente Fiche d'Homologation reproduit descriptions, illustrations et dimensions du moteur au moment de l'homologation CIK-FIA.	<i>This Homologation Form reproduces descriptions, illustrations and dimensions of the engine at the moment of the CIK-FIA homologation.</i>
	
Photo du moteur côté pignon / <i>Photo of engine drive side</i>	Photo du moteur côté opposé / <i>Photo of engine opposite side</i>
Signature et tampon de l'ASN / <i>Signature and stamp of the ASN</i>	Signature et tampon de la CIK-FIA / <i>Signature and stamp of the CIK-FIA</i>
	

## INFORMATIONS TECHNIQUES / TECHNICAL INFORMATION

## A Caractéristiques / Characteristics

Le nombre de décimales doit être de 2 ou en accord avec la tolérance appliquée. / The number of decimal places must be 2 or comply with the relevant tolerance.		Tolérances et remarques / Tolerances & remarks
<b>Cylindre / Cylinder</b>		
Volume du cylindre / <i>Cylinder volume</i>	<b>59.85 cm<sup>3</sup></b>	< 60 cm <sup>3</sup>
Alésage d'origine / <i>Original bore</i>	<b>411.89 mm</b>	--
Alésage théorique maximum / <i>Maximum theoretical bore</i>	<b>&lt; 42.10 mm</b>	
Course / <i>Stroke</i>	<b>43.0 mm</b>	±0.1 mm
Nombre de lumières d'admission / <i>Number of intake ports</i>	<b>1</b>	--
Largeur des lumières d'admission* / <i>Width of intake ports*</i>	<b>26.0 mm</b>	+0.1/-0.2 mm
Nombre de conduits/lumières de transfert, cylindre/carter / <i>Number of transfer ports/ducts, cylinder/sump</i>	<b>2</b>	--
Largeur des lumières de transfert* / <i>Width of transfer ports*</i>	<b>25.5 mm</b>	+0.4/-0.2 mm
Nombre de lumières d'échappement / <i>Number of exhaust ports</i>	<b>1</b>	--
Largeur des lumières d'échappement* / <i>Width of exhaust ports*</i>	<b>28.0 mm</b>	+0.1/-0.2 mm
Forme de la chambre de combustion / <i>Shape of combustion chamber</i>	Gabarit / <i>Template</i> CIK	
<b>Vilebrequin / Crankshaft</b>		
Poids du vilebrequin complet, sans piston / <i>Weight of crankshaft complete, without piston</i>	<b>1225 gr.</b>	±3 % total
Dimensions des paliers / <i>Dimensions of bearings</i>	<b>20 x 47 x 14</b>	en/in mm
Type des paliers / <i>Type of bearings</i>	Roller bearing	
<b>Bielle / Conrod</b>		
Longueur (entre-axe) de la bielle / <i>Length between the axes of the conrod</i>	<b>88.0 mm</b>	±0.1 mm
Diamètre de la tête de bielle / <i>Diameter of big end</i>	<b>24 mm</b>	±0.05 mm
Diamètre du pied de bielle / <i>Diameter of small end</i>	<b>16 mm</b>	±0.05 mm
Poids de la bielle / <i>Weight of conrod</i>	<b>53.0 gr.</b>	minimum
<b>Piston / Piston</b>		
Nombre de segments du piston / <i>Number of piston rings</i>	<b>1</b>	--
Poids du piston, segments du piston inclus / <i>Weight of the piston including piston rings</i>	<b>59.9 gr</b>	±10 % total
Taille de l'axe de piston / <i>Size of gudgeon pin</i>	<b>34.8 x 12 mm</b>	±0.8 mm
Poids de l'axe de piston / <i>Weight of gudgeon pin</i>	<b>15.7 gr</b>	±10 % total

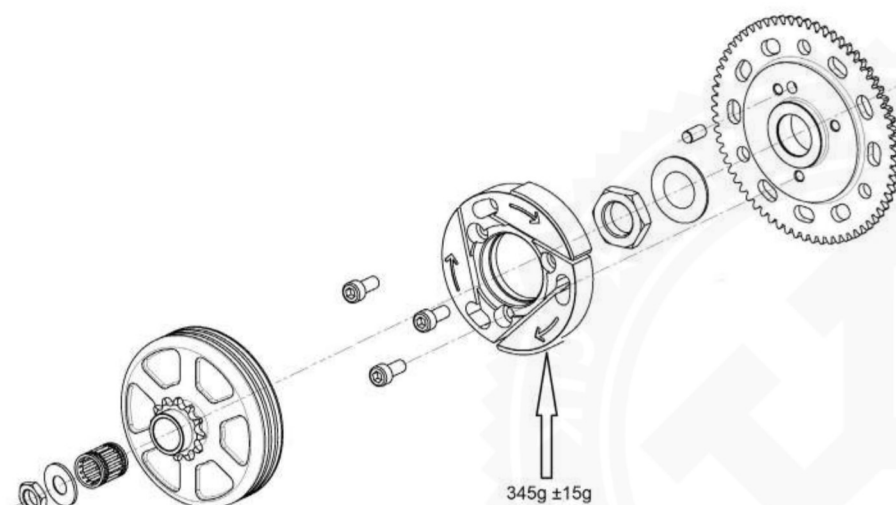
\* Toutes les dimensions peuvent être vérifiées à l'aide du gabarit du constructeur /  
All dimensions can be checked using the manufacturer's template

<b>B</b>	<b>Angles d'ouverture / Opening angles</b>		
	Lumière d'admission / Intake port	<b>144.0°</b>	+0 / -2°
	Lumière de transfert / Transfer port	<b>114.2°</b>	+0 / -2°
	Lumière d'échappement / Exhaust port	<b>156.0°</b>	+0 / -2°

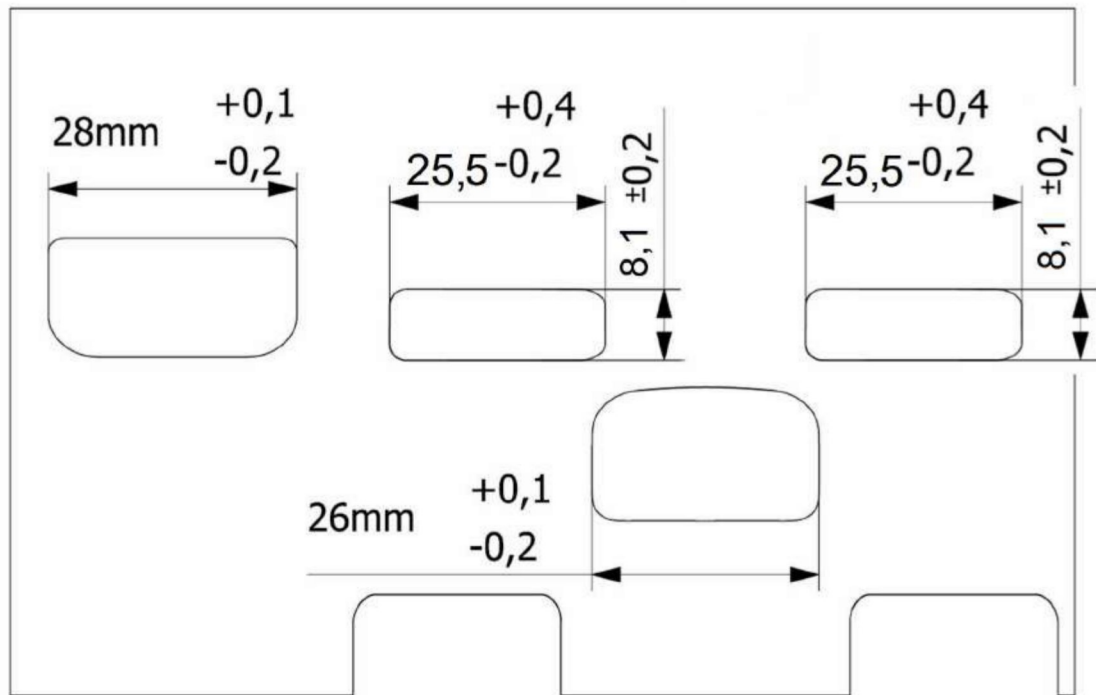
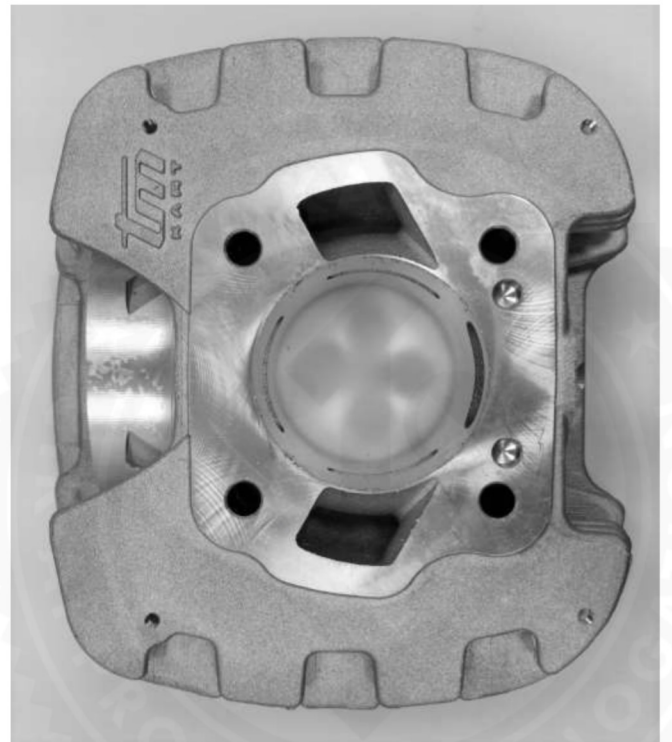
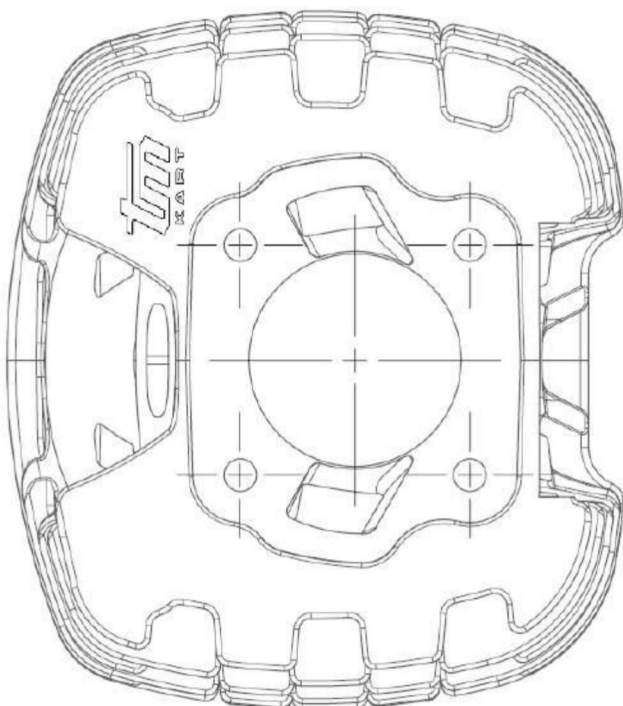
<b>C</b>	<b>Matériau / Material</b>	
	Culasse / Cylinder head	Aluminium-silicon alloy
	Cylindre / Cylinder	Aluminium-silicon alloy
	Carter / Sump	Aluminium-silicon alloy
	Vilebrequin / Crankshaft	Nickel chromium molybdenum alloy
	Bielle / Connecting rod	Nickel chromium molybdenum alloy
	Piston / Piston	Aluminium alloy

<b>D</b>	<b>Embrayage / Clutch</b>		
	Poids de l'embrayage assemblé / Weight of the clutch assembly	<b>800 gr.</b>	minimum
	Dimensions de l'embrayage / Dimensions of the clutch	selon dessin technique n°3.4 / according to technical drawing no. 3.4	
	Poids de l'embrayage / Weight of the clutch	<b>345 gr.</b>	±15 gr
	Diamètre interne de la cloche d'embrayage / Internal diameter of clutch bell	<b>85.00 mm</b>	maximum

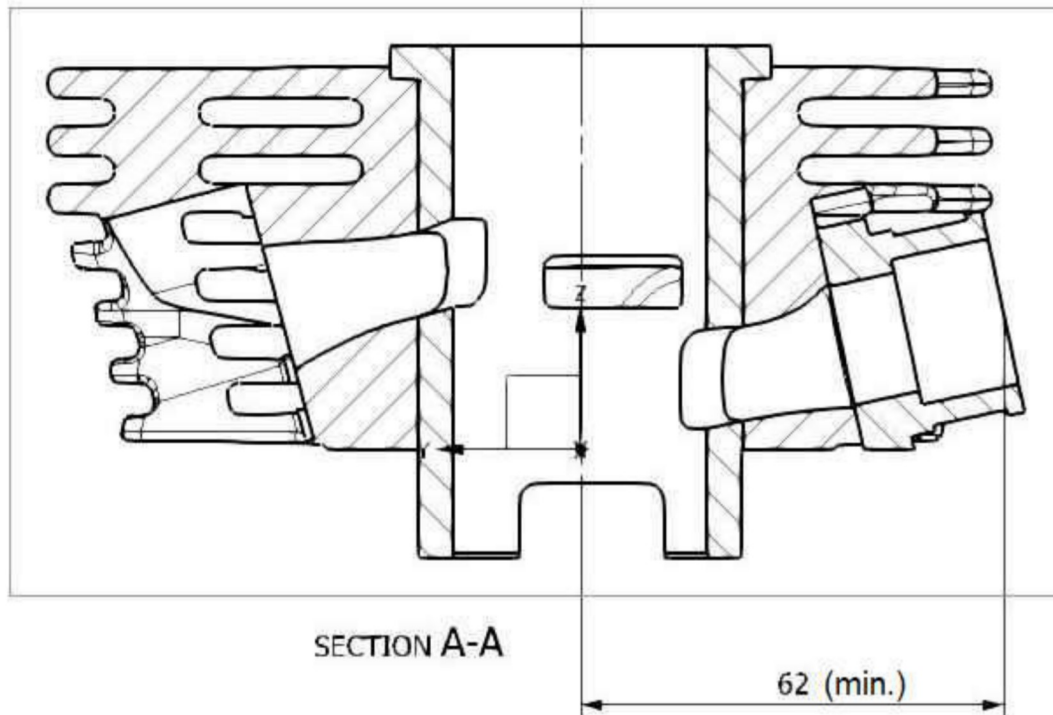
**Dessin de l'embrayage assemblé / Drawing of the clutch assembly**



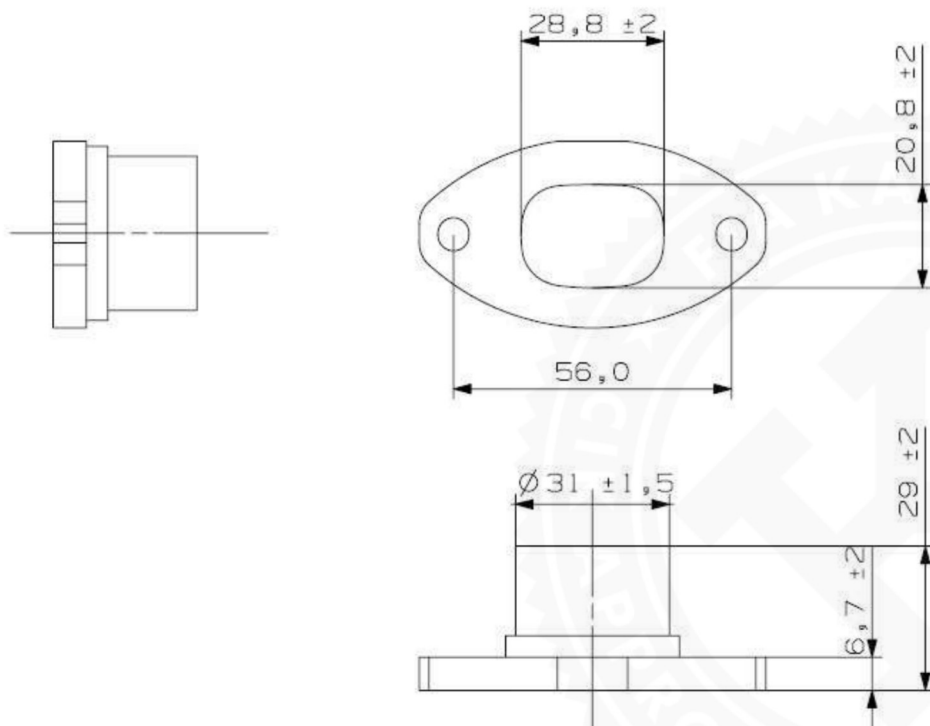
E

Photos, dessins et graphiques / *Photos, drawings and graphs*1. Cylindre / *Cylinder*Dessin du développement du cylindre (avec dimensions) / *Drawing of the cylinder development (with dimensions)*Dessin du pied du cylindre / *Drawing of the cylinder base*Photo du pied du cylindre / *Photo of the cylinder base*

Vue en coupe verticale du cylindre complet  
 (avec distance minimale de la surface d'appui du carburateur par rapport à l'axe du cylindre) /  
 Vertical cross section view of the complete cylinder  
 (with minimum distance of the carburettor support surface to cylinder axis)



Dessin du collecteur d'échappement (dimensions principales avec tolérances) /  
 Drawing of exhaust manifold (main dimensions with tolerances)



Dessin de la culasse et de la chambre de combustion (sans dimensions) /  
Drawing of the cylinder head and the combustion chamber (without dimensions)

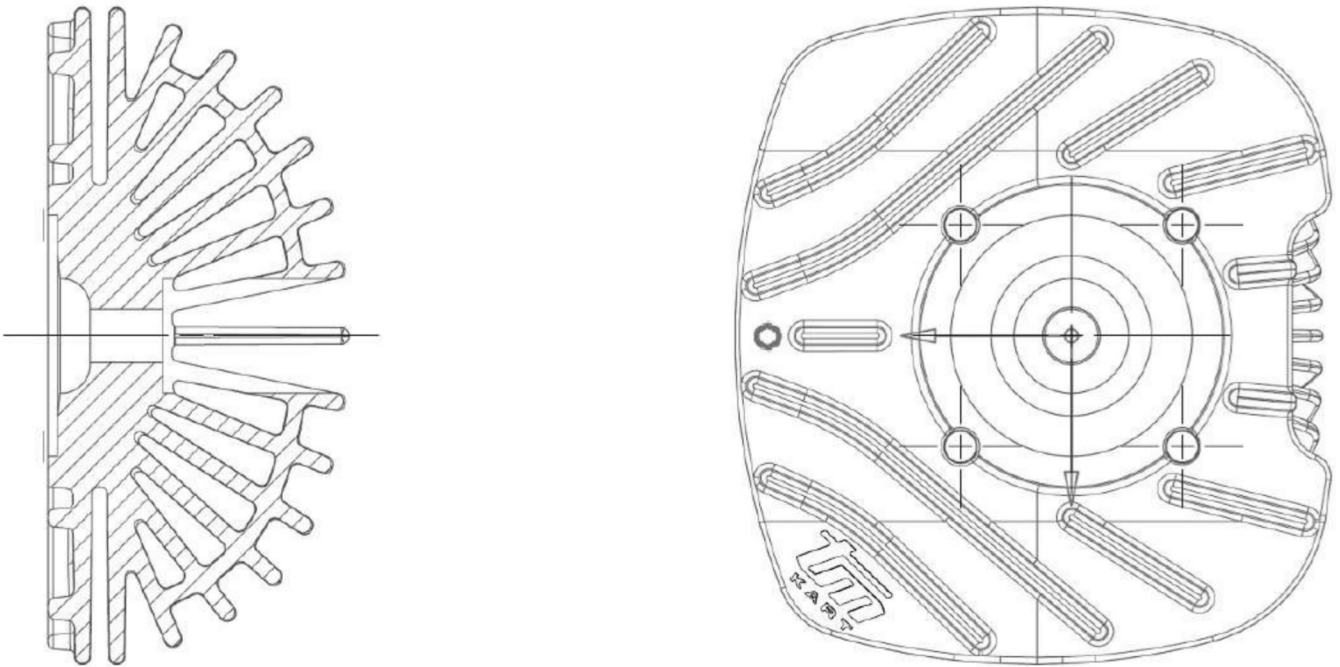
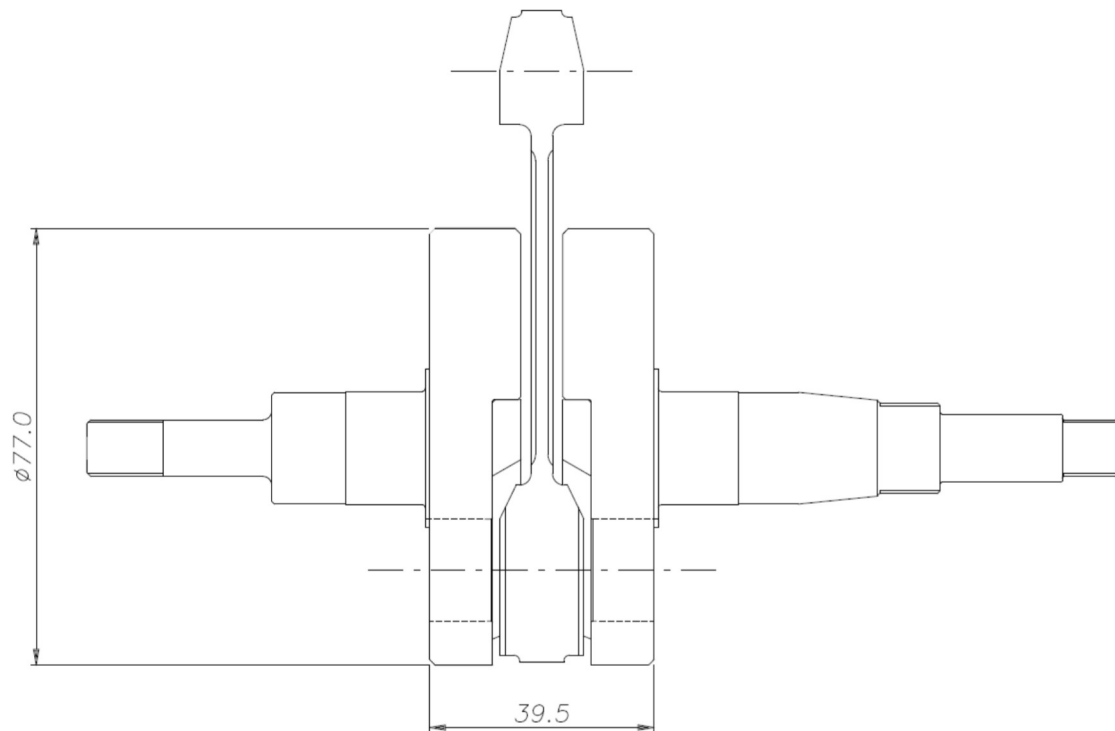


Photo de la culasse et de la chambre de combustion /  
Photo of the cylinder head and the combustion chamber



**2. Vilebrequin, bielle, piston et carter / Crankshaft, conrod, piston and crankcase**

Dessin du vilebrequin complet (dimensions sans tolérances) /  
Drawing of the complete crankshaft (dimensions without tolerances)



Photos de demi-vilebrequins (une avec contrepois en plastique, une sans) /  
Photos of crankshaft halves (one with plastic counterweight, one without)

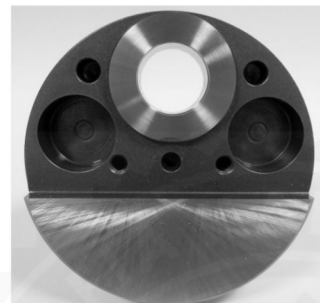
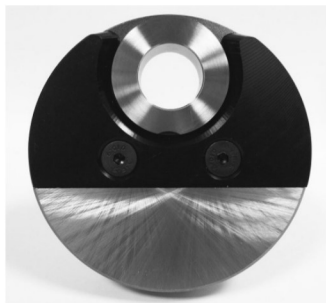


Photo du vilebrequin et de la bielle /  
*Photo of the crankshaft and conrod*



Photo de la bielle droite / *Photo of the conrod right*



Photo de la bielle gauche / *Photo of the conrod left*





Dessin du piston (dimensions principales sans tolérances et gabarit) /  
Drawing of the piston (main dimensions without tolerances and template)

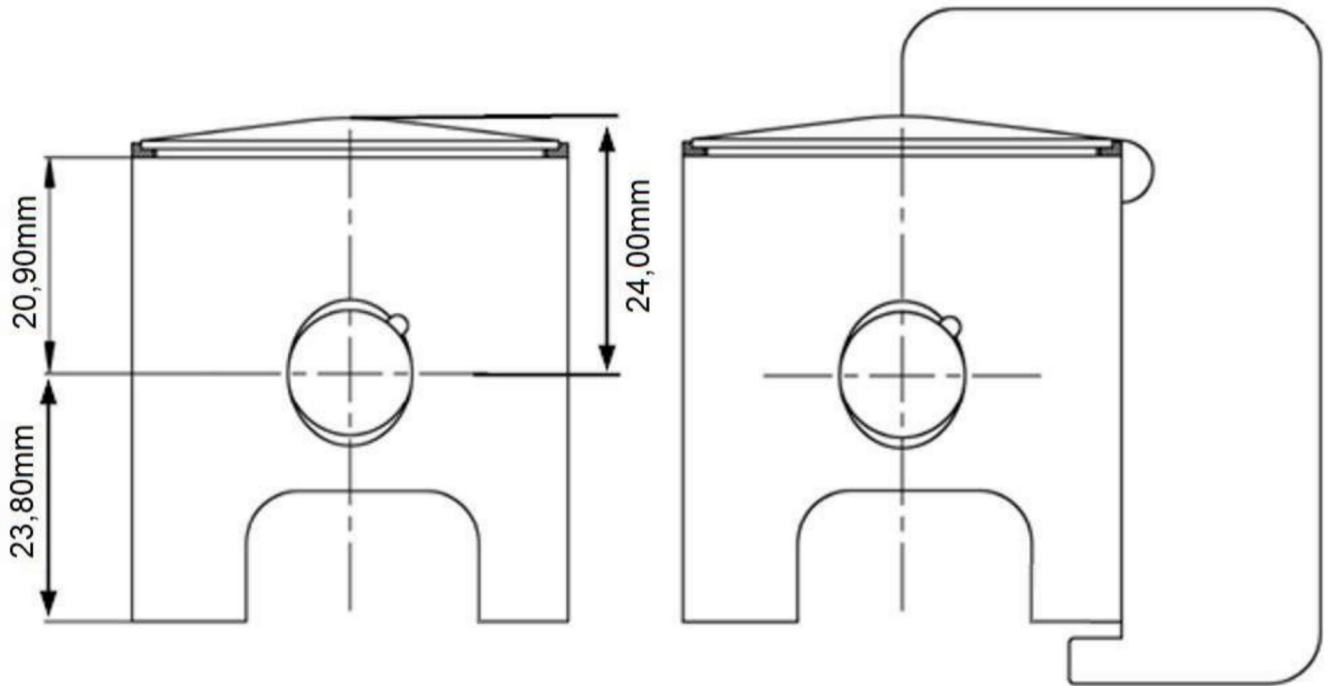


Photo du piston (de l'avant, de côté et d'en haut) / Photo of the piston (front, side and top)



Photo de l'intérieur du carter droit /  
Photo of the inside of the right crankcase

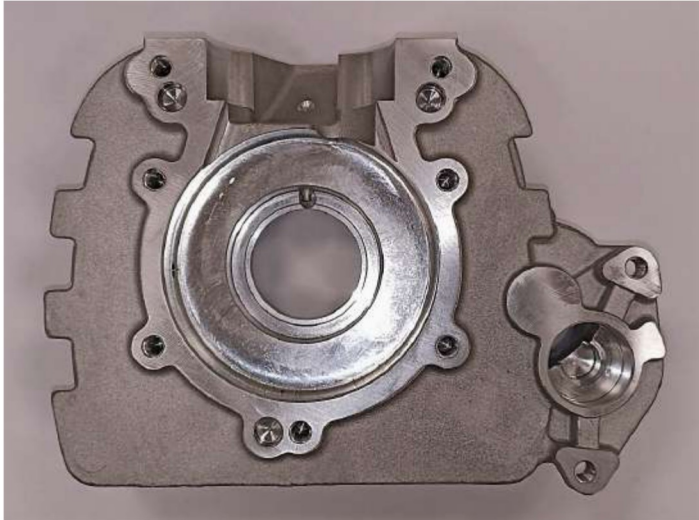


Photo de l'intérieur du carter gauche /  
Photo of the inside of the left crankcase



Photo de l'extérieur du carter droit /  
Photo of the outside of the right crankcase

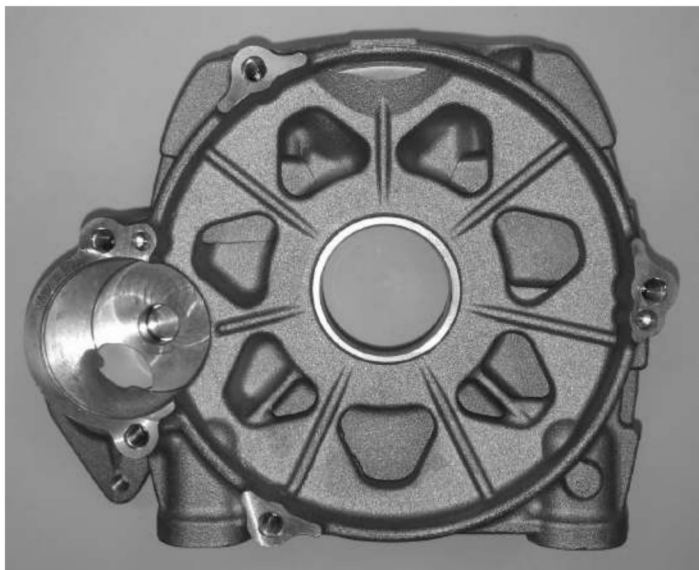


Photo de l'extérieur du carter gauche /  
Photo of the outside of the left crankcase



## 3. Moteur / Engine

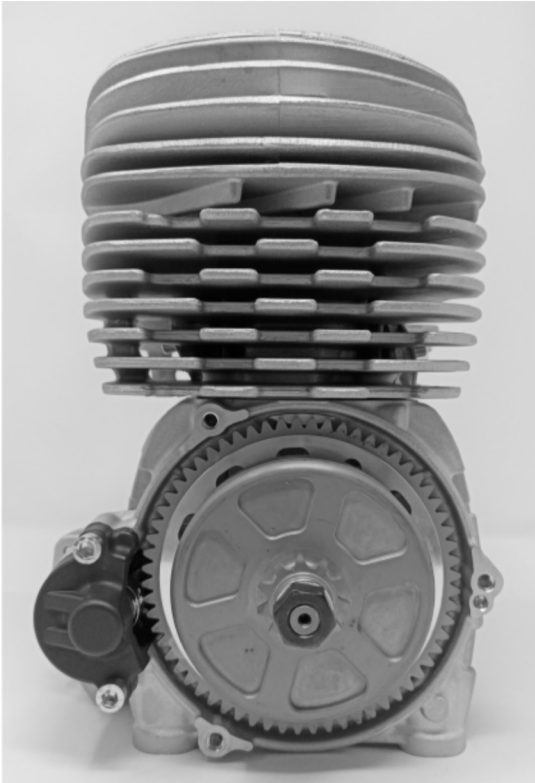
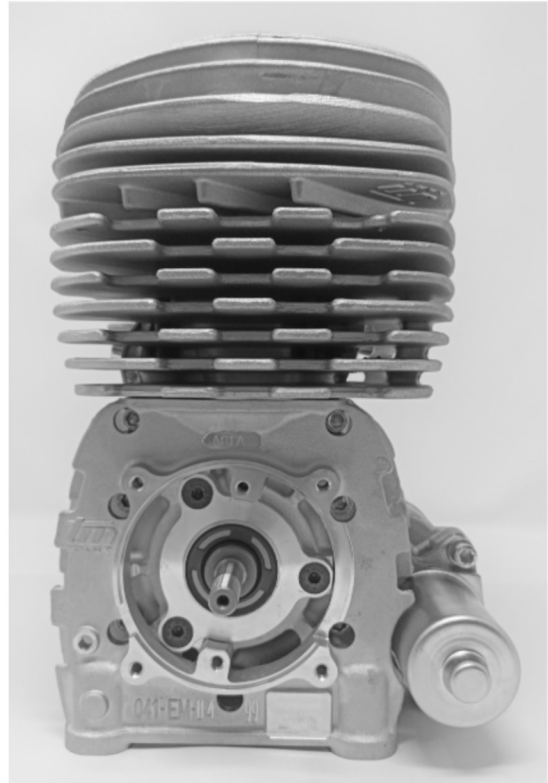
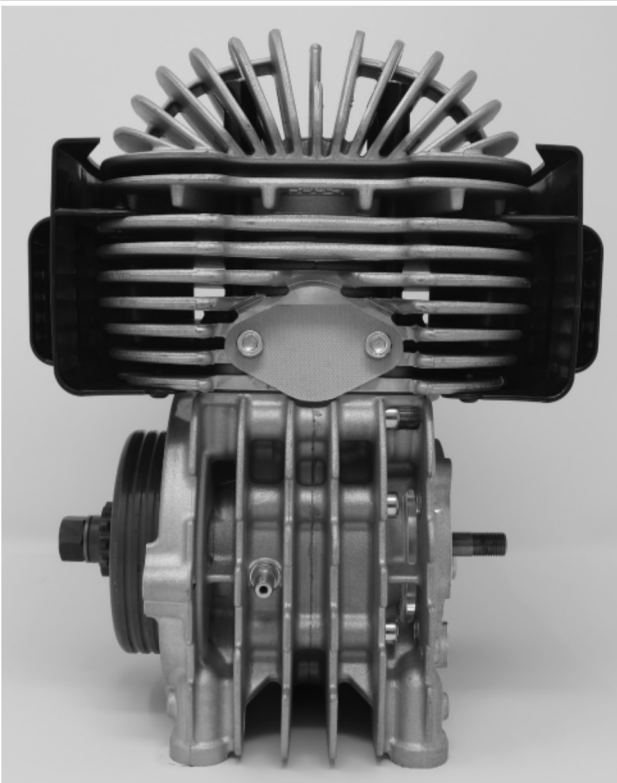
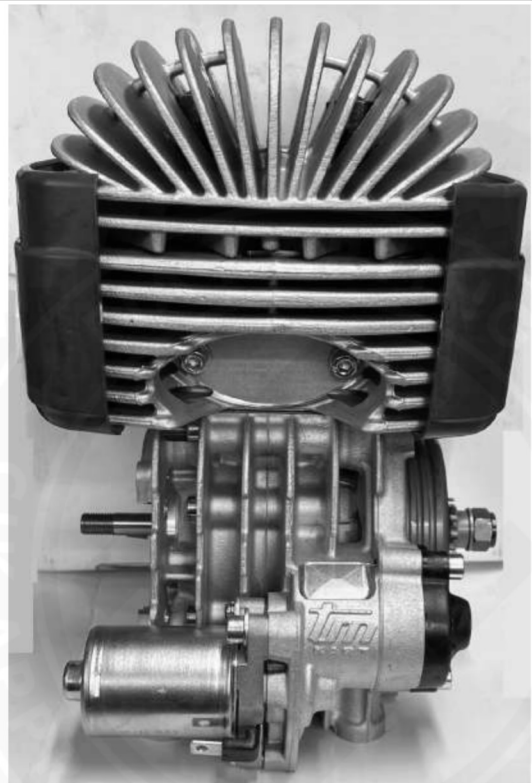
Photo du moteur côté pignon /  
Photo of engine drive sidePhoto du moteur côté opposé /  
Photo of engine opposite sidePhoto du moteur complet vu de l'avant /  
Photo of the complete engine front sidePhoto du moteur complet vu de l'arrière /  
Photo of the complete engine rear side

Photo du moteur complet vu du haut /  
Photo of the complete engine taken from above

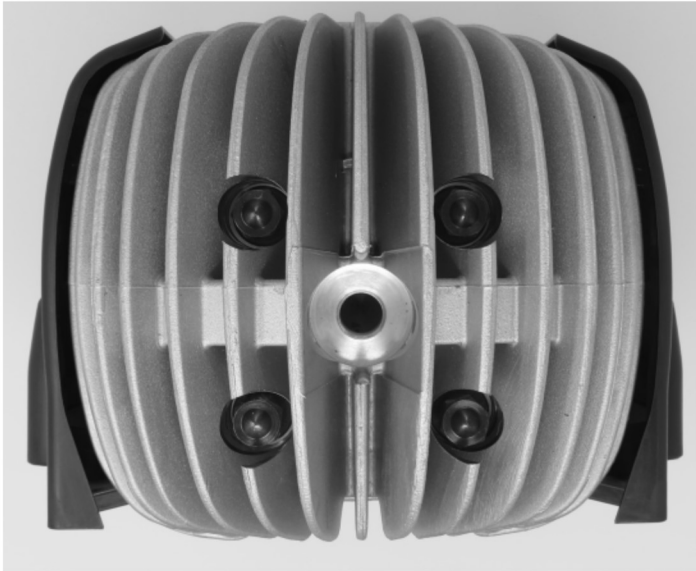


Photo du moteur complet vu du dessous /  
Photo of the complete engine taken from below

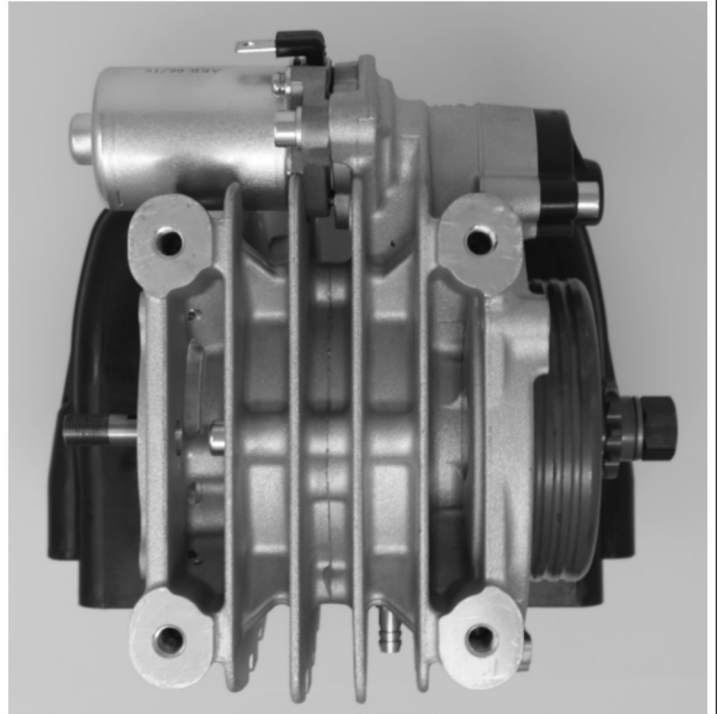


Photo des pièces plastiques du cylindre /  
Photo of the cylinder plastic parts



Photo du protège-chaîne et du couvercle d'allumage /  
Photo of the chain guard and ignition cover









F

**Marquage des pièces principales / Main parts marking**

Pour chaque pièce, photo d'ensemble avec le marquage et photo avec zoom sur le marquage /  
For each part, overall photo with marking and zoomed photo of marking

1. Fonderies des carters droit et gauche
2. Cylindre
3. Culasse
4. Chemise en fonte
5. Demi-vilebrequins
6. Bielle
7. Piston

1. Castings of LH & RH crankcases
2. Cylinder
3. Cylinder head
4. Cast iron liner
5. Half-crankshafts
6. Conrod
7. Piston

Pièces N° / Parts no.	Photo d'ensemble / Overall picture	Zoom
1		
1		
2		

3		
4		
5		
6		
7		