

# FICHE D'HOMOLOGATION HOMOLOGATION FORM



## COMMISSION INTERNATIONALE DE KARTING - FIA



### MOTEUR / ENGINE KZ1 / KZ2

Constructeur	<i>Manufacturer</i>	<b>TM RACING S.P.A.</b>
Marque	<i>Make</i>	<b>TM RACING</b>
Modèle	<i>Model</i>	<b>K9-C</b>
Type d'admission	<i>Inlet type</i>	<b>REED VALVE</b>
Durée de l'homologation	<i>Validity of the homologation</i>	9 ans / 9 years
Nombre de pages	<i>Number of pages</i>	9

La présente Fiche d'Homologation reproduit descriptions, illustrations et dimensions du moteur au moment de l'homologation CIK-FIA. Le Constructeur a la possibilité de les modifier seulement dans les limites fixées par le Règlement CIK-FIA en vigueur. La hauteur du moteur complet sur les photos doit être de 7cm minimum.

*This Homologation Form reproduces descriptions, illustrations and dimensions of the engine at the moment of the CIK-FIA homologation. The Manufacturer may modify them, but only within the limits fixed by the CIK-FIA Regulations in force. The height of complete engines on all photos must be minimum 7cm.*



PHOTO DU MOTEUR CÔTÉ PIGNON  
PHOTO OF DRIVE SIDE OF ENGINE

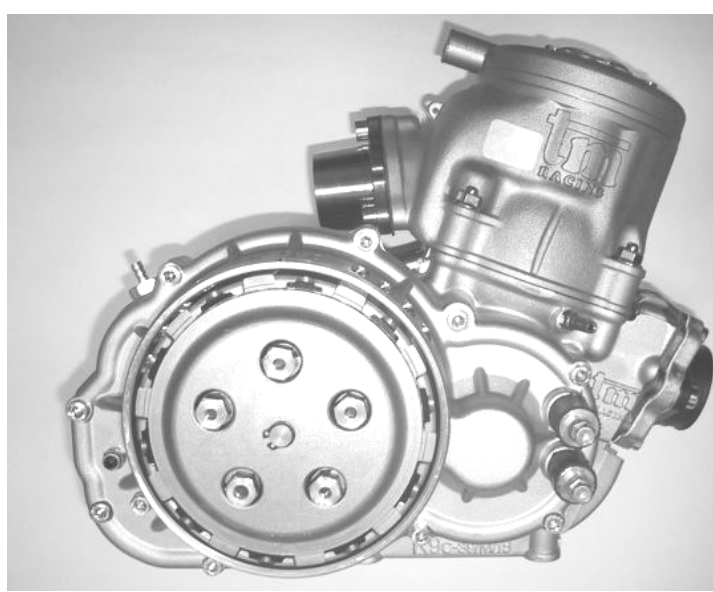

PHOTO DU MOTEUR CÔTÉ OPPOSÉ  
PHOTO OF OPPOSITE SIDE OF ENGINE

Signature et tampon de l'ASN  
*Signature and stamp of the ASN*

Signature et tampon de la CIK-FIA  
*Signature and stamp of the CIK-FIA*



*Glauco*



*[Signature]*

INFORMATIONS TECHNIQUES		TECHNICAL INFORMATION	
A	CARACTÉRISTIQUES	A	CHARACTERISTICS
			Tolérances
Volume du cylindre	<i>Volume of cylinder</i>	<b>124.66 CM3</b>	<b>&lt; 125cm<sup>3</sup></b>
Alésage d'origine	<i>Original Bore</i>	<b>54 MM</b>	
Alésage théorique maximum	<i>Theoretical maximum bore</i>	<b>54.07 MM</b>	
Course	<i>Stroke</i>	<b>54.43 MM</b>	
Système de refroidissement	<i>Cooling system</i>	<b>WATER</b>	
Nombre de systèmes de carburation	<i>Number of carburation systems</i>	<b>1 CARBURATOR</b>	
Nombre de canaux de transfert, cylindre/carter	<i>Number of transfer ducts, cylinder/sump</i>	<b>5</b>	
Nombre de lumières / canaux d'échappement	<i>Number of exhaust ports / ducts</i>	<b>3</b>	
Forme de la chambre de combustion	<i>Shape of the combustion chamber</i>	<b>SPHERIC WITH VARIABLE RADIUS+SQUISH</b>	
Matériau de la paroi du cylindre	<i>Cylinder wall material</i>	<b>ALLUMINIUM+NICASIL</b>	
Longueur (entre-axe) de la bielle	<i>Length between the axes of the connecting rod</i>	<b>109.8</b>	±0.1mm
Volume de la chambre de combustion	<i>Volume of combustion chamber</i>	<b>11 CC</b>	Minimum
Nombre de segments de piston	<i>Number of piston rings</i>	<b>1</b>	
Modifications autorisées selon le Règlement Technique. Seules les dimensions et cotes qui ne peuvent pas être modifiées doivent figurer sur la Fiche d'Homologation. <i>Modification allowed according to the Technical Regulations. Only the dimensions and readings which may not be changed must be mentioned on the Homologation Form.</i>			

B	ANGLES D'OUVERTURE	B	OPENING ANGLES
De l'échappement	<i>Exhaust</i>	<b>199°</b>	Max

C	MATÉRIAU	C	MATERIAL
Cylindre	<i>Cylinder</i>		<b>ALLUMINIUM+NICASIL</b>
Culasse	<i>Cylinder head</i>		<b>ALLUMINIUM</b>
Carter	<i>Sump</i>		<b>ALLUMINIUM+STEEL'S BUSH</b>
Bielle	<i>Connecting rod</i>		<b>STEEL</b>

DESSIN DU DÉVELOPPEMENT DU CYLINDRE

DRAWING OF THE CYLINDER DEVELOPMENT

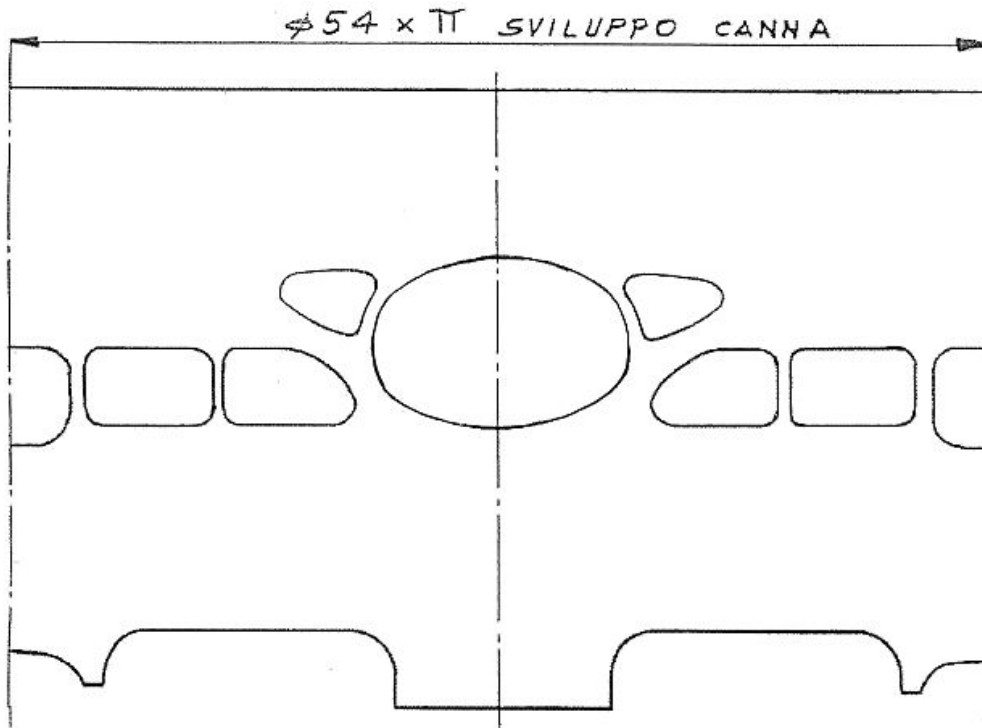
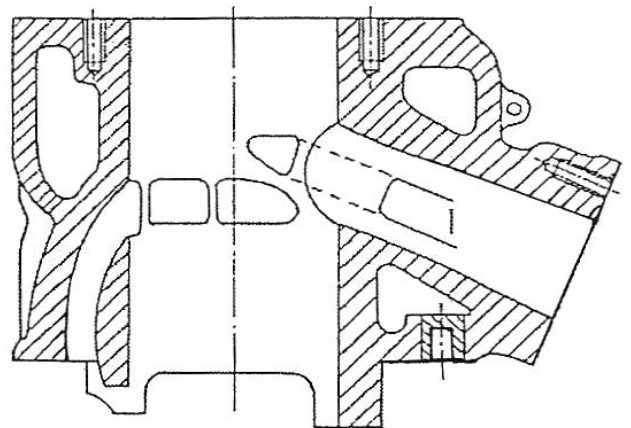
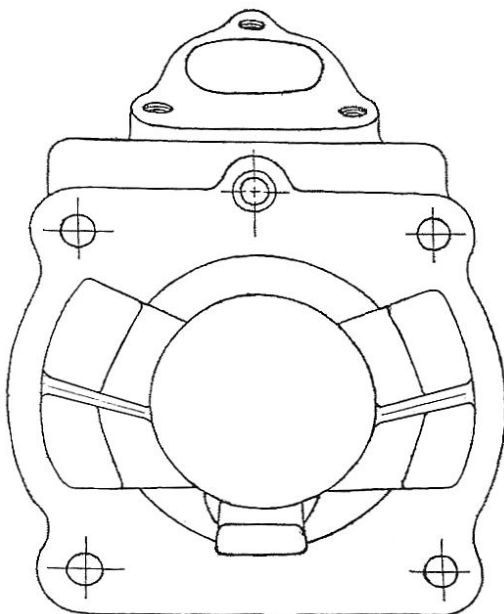
DESSIN DU PIED DU  
CYLINDREDRAWING OF THE  
CYLINDER BASEVUE EN SECTION DU  
CYLINDRESECTION VIEW OF  
CYLINDER

DESSIN DE LA CULASSE ET DE LA CHAMBRE  
DE COMBUSTION

DRAWING OF THE CYLINDER HEAD AND OF  
THE COMBUSTION CHAMBER

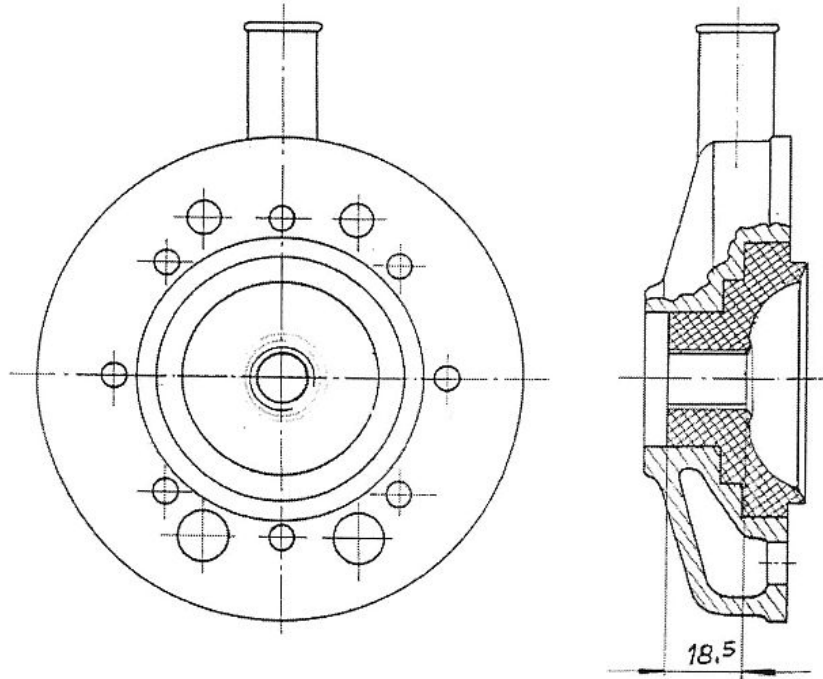

DESSIN DU  
VILEBREQUIN

DRAWING OF THE  
CRANKSHAFT

DESSIN INTÉRIEUR  
DU CARTER

DRAWING OF THE  
INSIDE OF SUMP

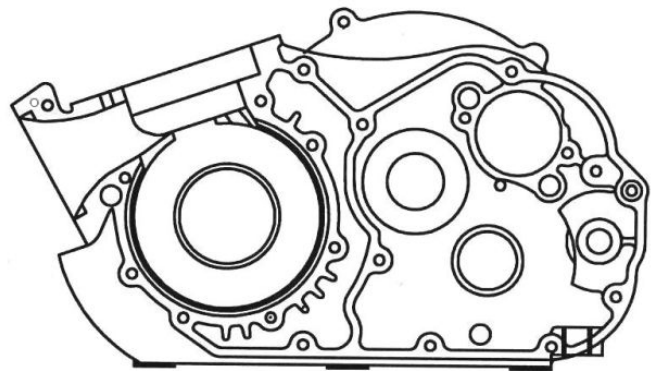
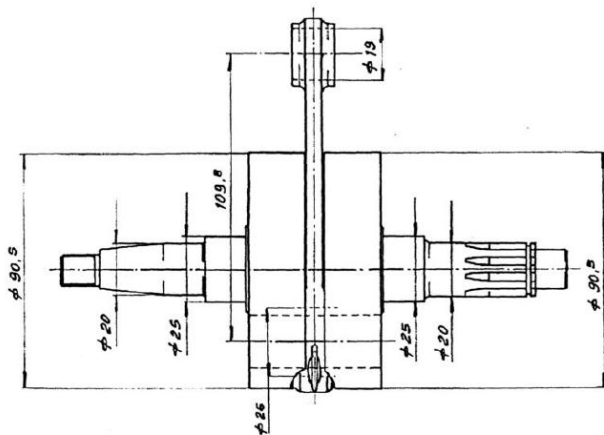





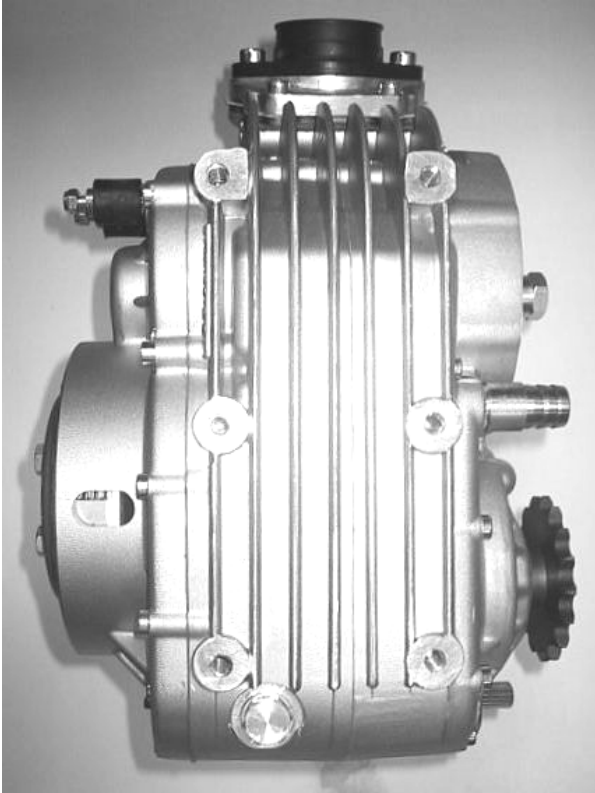

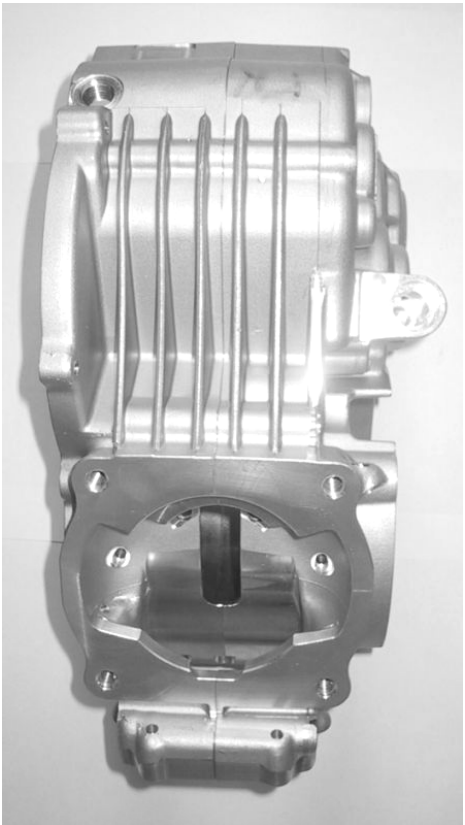

PHOTO DE L'ARRIÈRE DU MOTEUR	<i>PHOTO OF THE BACK OF THE ENGINE</i>	PHOTO DE L'AVANT DU MOTEUR	<i>PHOTO OF THE FRONT OF ENGINE</i>
			
PHOTO DU MOTEUR PARTIE SUPÉRIEURE	<i>PHOTO OF THE ENGINE TAKEN FROM ABOVE</i>	PHOTO DU MOTEUR PARTIE INFÉRIEURE	<i>PHOTO OF THE ENGINE TAKEN FROM BELOW</i>
			

PHOTO DU PIED DU CYLINDRE	<i>PHOTO OF THE BASE OF THE CYLINDER</i>	PHOTO DE LA CHAMBRE DE COMBUSTION	<i>PHOTO OF COMBUSTION CHAMBER</i>
			
PHOTO DU CARTER (CÔTÉ JOINT)	<i>PHOTO OF THE SUMP (GASKET FACE)</i>	PHOTO D'UNE PARTIE INTÉRIEURE DU CARTER	<i>PHOTO OF AN INTERNAL PART OF THE SUMP</i>
			

## DESSIN DE LA BOÎTE À CLAPETS

## DRAWING OF REED VALVE

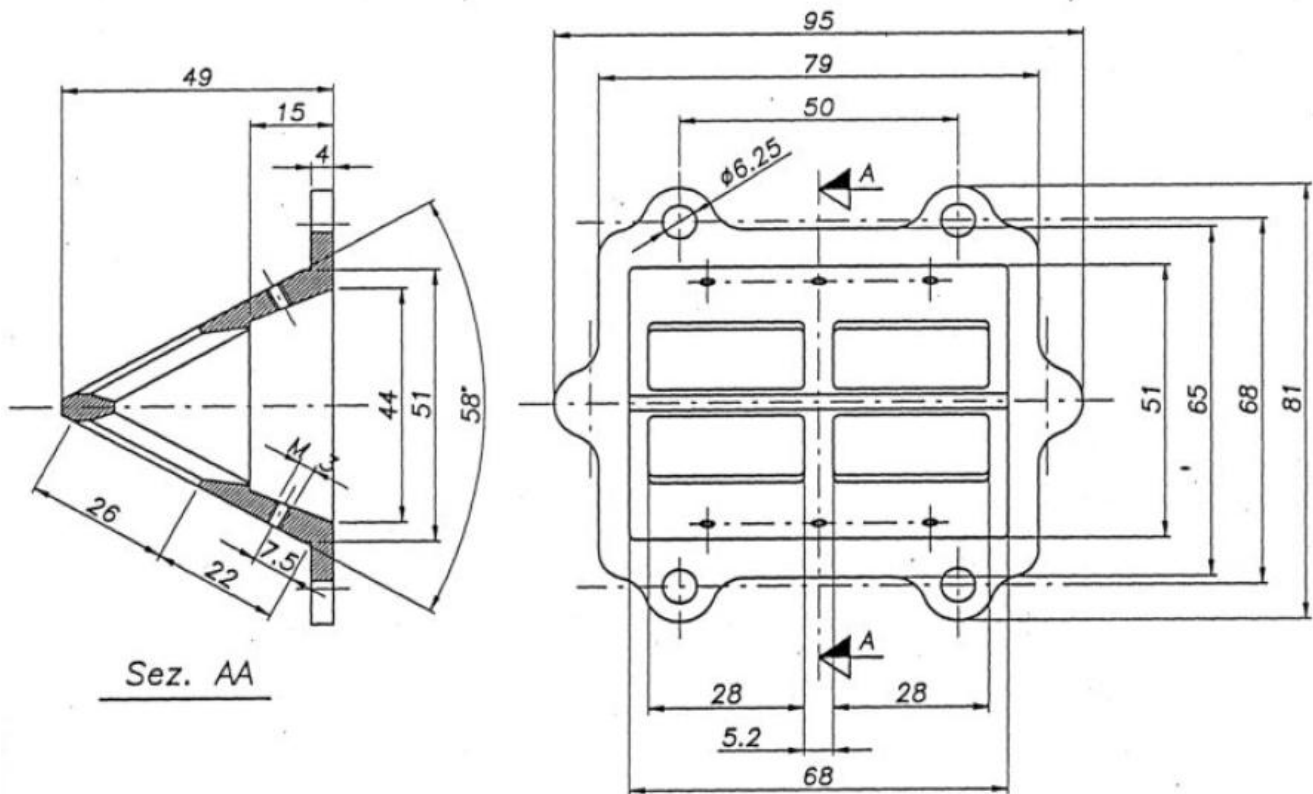

## DESSIN DU COUVERCLE DE LA BOÎTE À CLAPETS

## DRAWING OF REED VALVE COVER

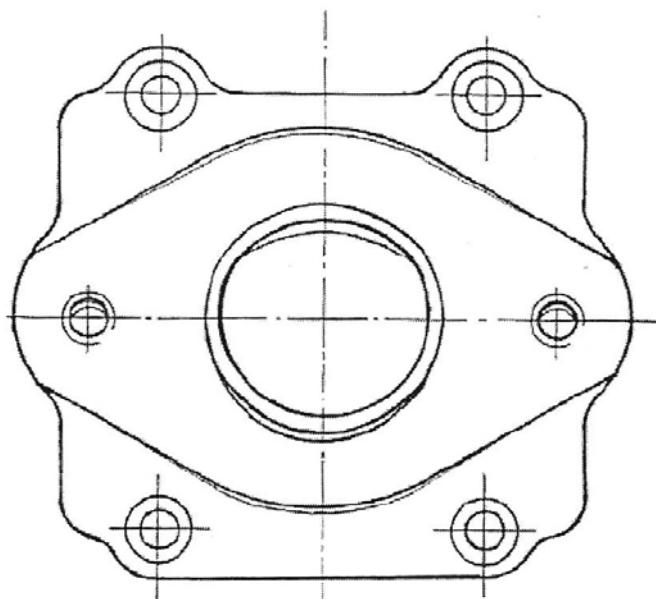

BOÎTE DE VITESSES		GEARBOX	
Couple primaire		<i>Primary coupling</i>	
		<b>19/75</b>	
Rapports de boîte de vitesses		<i>Gearbox ratios</i>	
Vitesse	Arbre primaire	Arbre secondaire	Relevé des valeurs obtenues après trois tours moteur
<i>Gear</i>	<i>Primary shaft</i>	<i>Secondary shaft</i>	<i>Reading of values obtained after three engine revs</i>
1 <sup>ère</sup> /1 <sup>st</sup>	<b>13</b>	<b>33</b>	<b>107.8°</b>
2 <sup>e</sup> /2 <sup>nd</sup>	<b>16</b>	<b>29</b>	<b>151.0°</b>
3 <sup>e</sup> /3 <sup>rd</sup>	<b>18</b>	<b>27</b>	<b>182.4°</b>
4 <sup>e</sup> /4 <sup>th</sup>	<b>22</b>	<b>27</b>	<b>222.9°</b>
5 <sup>e</sup> /5 <sup>th</sup>	<b>22</b>	<b>23</b>	<b>261.7°</b>
6 <sup>e</sup> /6 <sup>th</sup>	<b>27</b>	<b>25</b>	<b>295.5°</b>

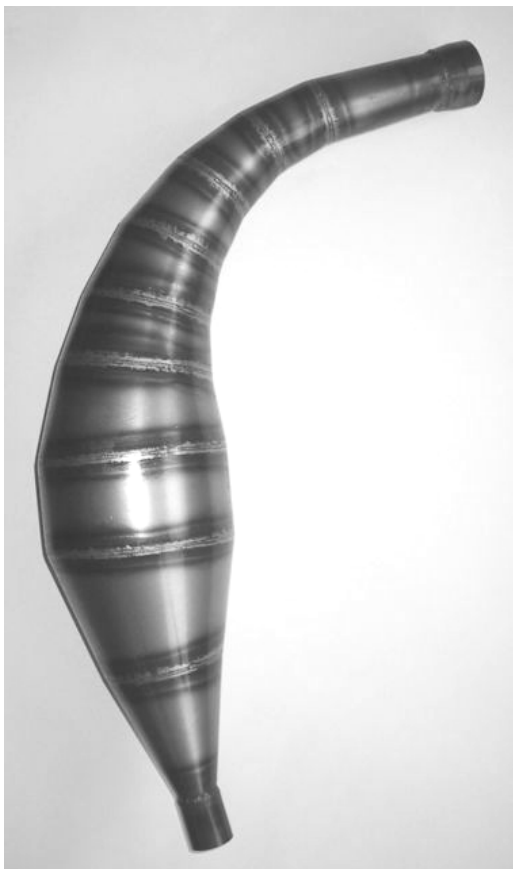
PHOTOS DE L'ÉCHAPPEMENT	PHOTOS OF THE EXHAUST
	



DESCRIPTIONS TECHNIQUES		TECHNICAL DESCRIPTIONS	
Poids en gr	Weight in gr	<b>1080</b>	Minimum
Volume in cm <sup>3</sup>	Volume in cc	<b>4010</b>	+/-5 %

DESSINS TECHNIQUES	TECHNICAL DRAWINGS
Contenant toutes les informations permettant de construire cet échappement.	Including all the information necessary to build this exhaust.

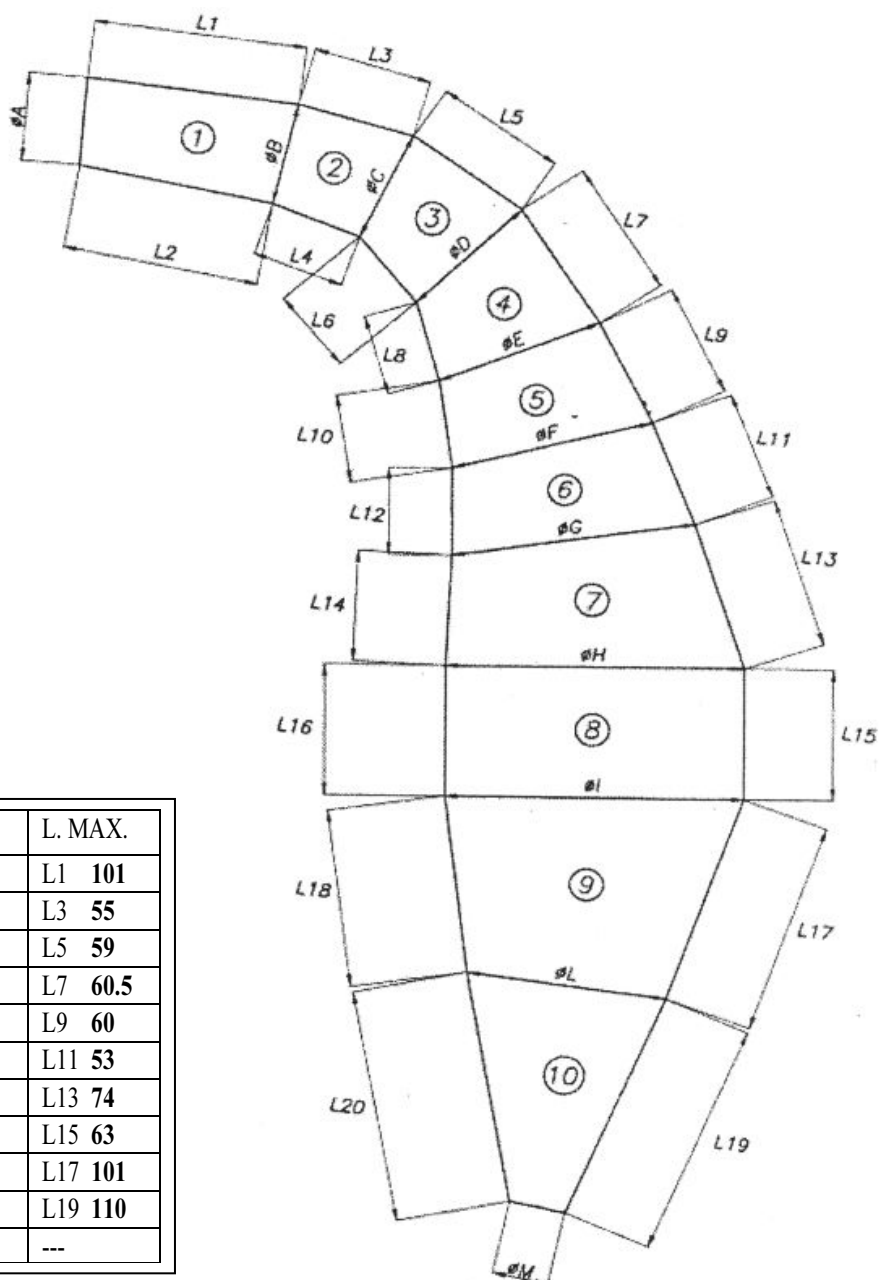

Partie/Part	D. MIN.	D. MAX	L. MIN.	L. MAX.
1	ØA 42.8	ØB 49	L2 93.5	L1 101
2	ØB 49	ØC 54	L4 43	L3 55
3	ØC 54	ØD 66	L6 44	L5 59
4	ØD 66	ØE 80	L8 42	L7 60.5
5	ØE 80	ØF 95	L10 41.3	L9 60
6	ØF 95	ØG 112	L12 38.5	L11 53
7	ØG 112	ØH 137	L14 51.5	L13 74
8	ØH 137	ØI 137	L16 63	L15 63
9	ØI 137	ØL 87.5	L18 84	L17 101
10	ØL 87.5	ØM 25.7	L20 110	L19 110
---	---	---	---	---